

APPLICATION:

- Bench mounting

DETAILS:

- Test pressure: 9 Bars/air
- Max working pressure: 5 Bars
- Flow rate limited to 14L/min

SURFACE PROTECTION:

- Chemical nickel plating

MATERIALS:

- Brass
- ABS
- EPDM
- Stainless steel

HEADWORK SEALING:

- EPDM temperature working range: 0-70°

CONNECTION TAP:

- Swivelling cup G1/2" female

STANDARD AND NORMS:

- DIN4844-2-D and BGV A8
- DIN1988 - DIN EN 1717
- DIN EN 15154-2:2006
- ANSA Z358.1-2004

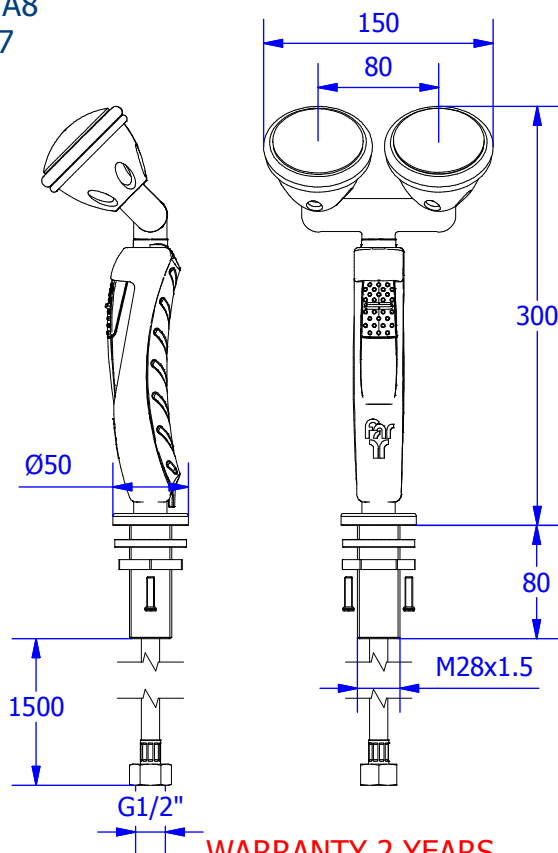
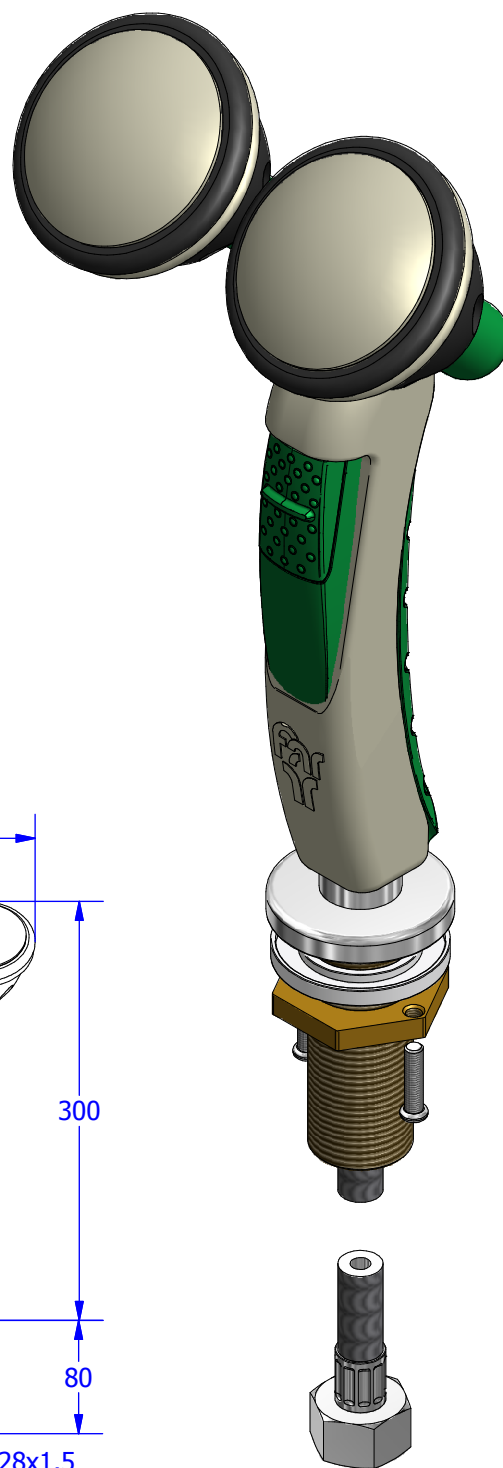
**WEIGHT:**

-

WARRANTY 2 YEARS

Nuova FAR
Rubinetterie

Disegnato da

Davide Riva

Approvato da

Michele Albertone

Verificato da

Michele Albertone

Data di emissione: 08/11/2011

Peso:

Scala: 1:4

Il presente disegno a termine di legge non può essere riprodotto o reso pubblico senza la nostra autorizzazione scritta.

DISEGNATO CON CAD NON MODIFICABILE A MANO