

DESCRIZIONE: SINGLE NOZZLE BENCH SPRAY UNIT VERTICAL EXTRACTING

Codice disegno: 32100-45MDS

**APPLICATION:**

- Bench mounting

**DETAILS:**

- Test pressure: 9 Bars/air
- Max working pressure: 5 Bars
- Flow rate limited to 7L/min

**SURFACE PROTECTION:**

- Chemical nickel plating

**MATERIALS:**

- Brass
- ABS
- EPDM
- Stainless steel

**HEADWORK SEALING:**

- EPDM temperature working range: 0-70°

**CONNECTION TAP:**

- Swivelling cup G1/2" female

**STANDARD AND NORMS:**

- DIN4844-2-D and BGV A8
- DIN1988 - DIN EN 1717
- DIN EN 15154-2:2006
- ANSA Z358.1-2004

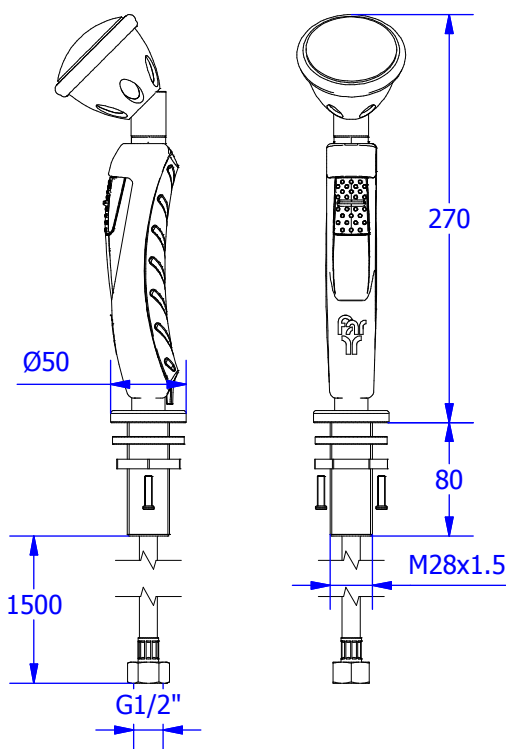
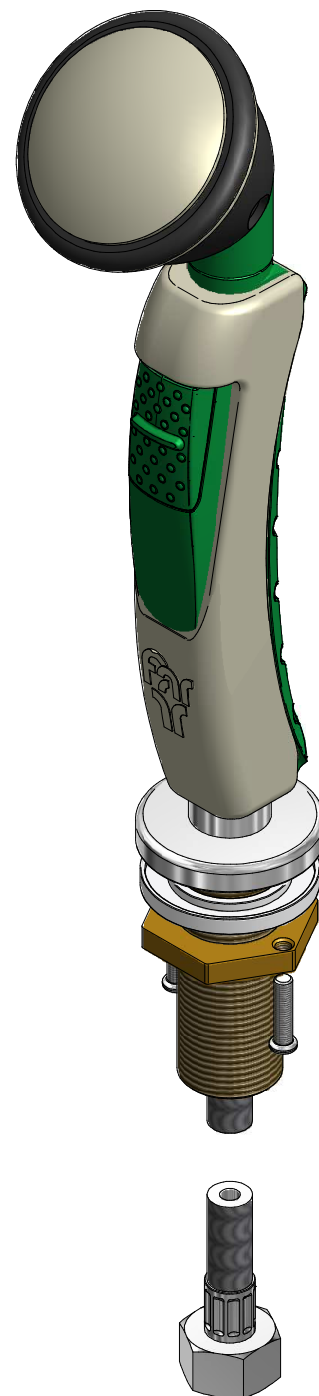

**WEIGHT:**

- 

**WARRANTY 2 YEARS**



**Nuova FAR  
Rubinetterie**

Disegnato da

Davide Riva

Approvato da

Michele Albertone

Verificato da

Michele Albertone

Data di emissione: 08/11/2011

Peso:

Scala: 1:4

Il presente disegno a termine di legge non può essere riprodotto o reso pubblico senza la nostra autorizzazione scritta.

**DISEGNATO CON CAD NON MODIFICABILE A MANO**